



308 Industrial Park Road, Starkville, MS 39759 USA  
 Pit: (662) 323-9538 FAX: (662) 323-6551

# LJ-155CA

15 Meter, 5 Elements Long

John Mono Bander

## INSTRUCTION MANUAL

### WARNING

Installation of this product near power lines is dangerous. For your safety, follow the installation directions.

### General Description

The Hy-Gain Model 155CA is a computer optimized, high performance 5-element, 15-meter beam. The 155CA features five full sized elements on a 26 foot boom, a Hy-Gain adjustable Beta Match and a rugged boom-to-mast bracket.

The 155CA is ideal for stacking with other Hy-Gain monobanders, the 105BA-S and the 205CA, for unparalleled performance and durability. The 155CA now features stainless steel hardware for all electrical and most mechanical connections.

The new 155CA has been computer optimized to provide at least 24 dB front-to-back over the frequency range of 21.250 - 21.450 MHz for the "phone" setting, 21.150 - 21.350 MHz for the "Mid" setting, and 21.050 - 21.250 MHz for the "CW" setting. Maximum front-to-back is 25 dB on each setting (all backlobes). The power gain varies from 7.4 dBd at 21 MHz to 7.62 dBd at 21.450 MHz. Dimensions are also supplied to make the 125CA, a 5-element 12 Meter beam or the 155MAX, a 5-element 15 meter beam with 40 dB F/B at 21.250 MHz.

<b>Specifications</b>	
<i>Electrical</i>	
Power Gain*	9.75 dBi (7.6 dBd)
Front-to-Back* (all backlobes)	20 — 25 dB
VSWR (at resonance)	less than 1.5:1
Nominal Impedance	50 ohms
Power Rating	maximum legal
Matching Method	adjustable beta
2:1 Bandwidth	400 KHz
Horizontal Half power beam width*	55 degrees
<i>Mechanical</i>	
Boom	2" x 26' (5.1 cm x 7.92 m)
Turning Radius	approximately 17' 6" (5.33 m)
Longest Element	25' 1 1/4" (7.6 m)
Surface Area	5.2 sq. ft. (.483 sq. m)
Wind Load @ 80 mph	133 lbs. (60.3 kg)
Max. Wind Survival (no ice)	Elements: 88 mph (141.6 kmph) Boom: 153 mph (246.2 kmph)
Mast Diameter Accepted	1 1/4" to 2 1/2" (3.2 cm to 6.4 cm)
Hardware	18-8 stainless steel
Clamps	stainless steel

\*Gain, Front-to-back ratio and beam width verified by MININEC3 and YO computer codes along with radiation pattern measurements of full size antennas on liy-Gain's test range.

## Preparation for Assembly

**FOR OUR OVERSEAS CUSTOMERS:** If you use the Metric System, see American-to-Metric Conversion Table in the rear of this manual. The United States uses American units of weights and measures. Choose a large, clear area to assemble the 155CA. The area must be at least 26' x 26'(8 m x 8 m). You may wish to use sawhorses or chairs to support the boom during assembly. An alternate method involves driving a 5' (1.5 m) length of mast material into the ground and attaching the boom and boom-to-mast bracket to this mast temporarily during assembly. This permits eye level installation of parts and allows easy alignment of elements after assembly. If you assemble this antenna over a grassy area, precautions should be taken so that hardware is not accidentally lost during assembly. A concrete driveway is an excellent area for assembly.

**Tools:** The following tools are required for easy assembly of the 155CA:

Type of Tool	Qty
Tape Measure, 12 foot.....	1
Adjustable Wrench, 8 inch.....	2
Nut Driver, 7/16 inch.....	1
Nut Driver, 3/8 inch.....	1
Nut Driver, 5/16 inch.....	1
Standard Hand Pliers.....	1

When unpacking your antenna, check inside of all tubing parts. To conserve space, these smaller articles are sometimes put inside larger pieces. Check all parts against the Parts List to make sure no parts are missing. The hardware supplied with this antenna is bagged by thread size for your convenience.

All tubing supplied with the 155CA telescopes together. Make all measurements to the given dimensions, plus or minus, no more than 1/8 inch (3 mm)!

The assembly of this antenna will be easier if you read this manual completely through at least three (3) times before beginning assembly. Allow at least 5 hours for assembly. Double and triple check ALL dimensions after assembly.

## Boom Assembly

Select the cast aluminum brackets, boom-to-bracket clamp and casting-to-boom bracket and loosely assemble as shown in Figure 2. The bracket must be loose in order to finish the assembly of the boom.

Select the two center boom sections and slip the unswaged end of each into the boom-to-mast bracket. Align the holes in the boom with the holes in the bracket and secure as shown in Figure 2.

Install the outer boom sections as shown in Figure 3.

## Assembly of Element-to-Boom Brackets

Select the set of large element-to-boom brackets (Item No. 4) and loosely assemble as shown in Figure 4.

Select the remaining four sets of element-to-boom brackets (Item No. 3) and loosely assemble as shown in Figure 4.

Slide each assembled bracket over a boom end and position them as shown in Figure 1.

At this time, you must decide which mode of transmission you will use - either CW, Phone, or Mid-Band.

## CAUTION

*When you have selected your mode of transmission, you must use the same mode for the remaining measurement. DO NOT try to use averages or various combinations of measurement settings on the same element or serious deterioration in the antenna performance will result. The VS" Chart shown in Figure 6 should help you decide. which mode to select.*

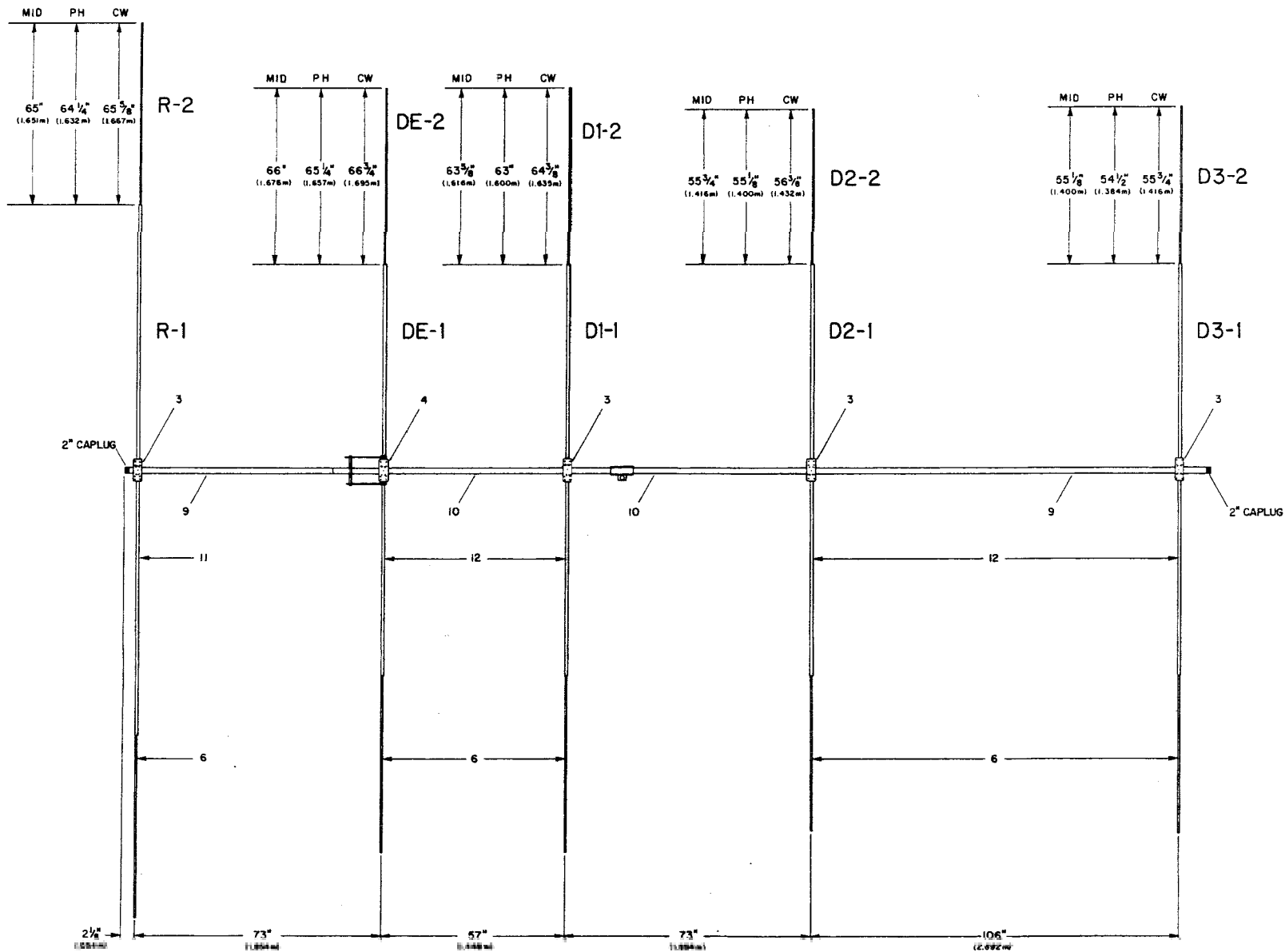
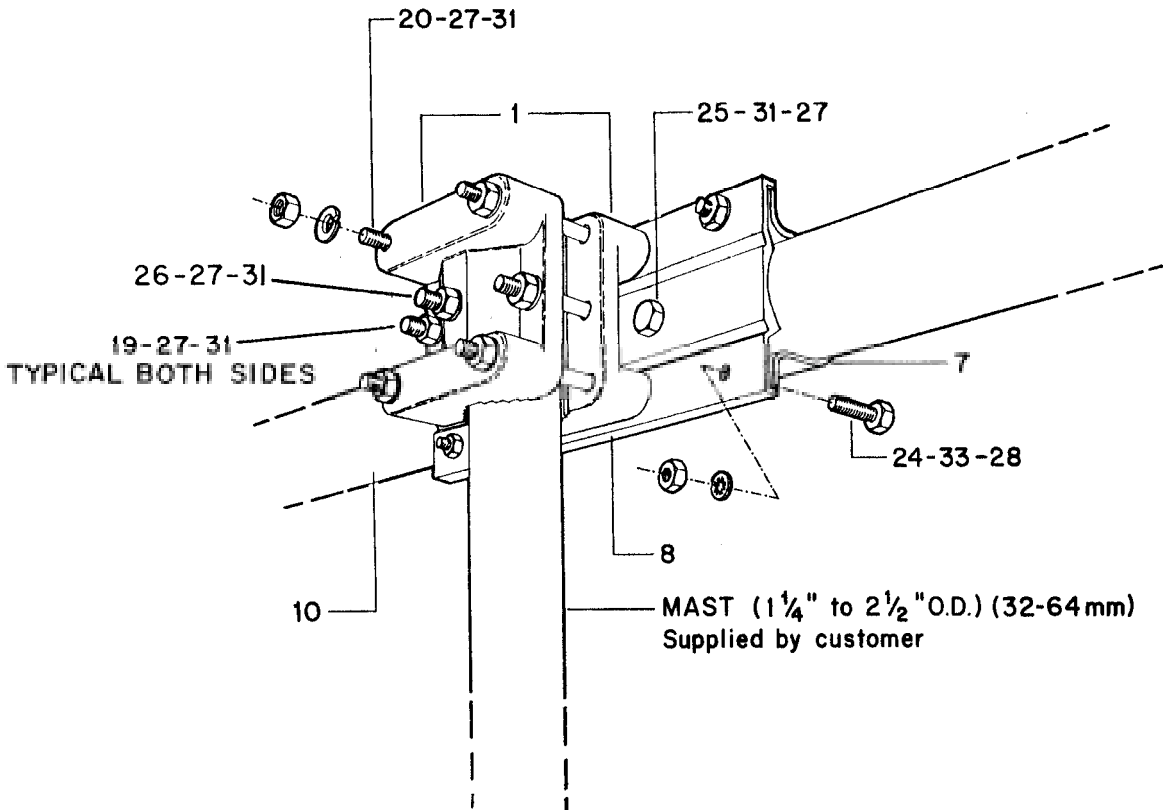

Figure 1  
155CA Overall View

NOTE: See OPTIONS for Maximum front-to-back setting and 12 meter setting.

Item No.	Description
3	Bracket, Element-to-Boom, #4
4	Bracket, Element-to-Boom, #13
6	Tube, 7/16" x 68"
9	Tube, Boom Section, 2" x 79"
10	Tube, Inner Boom, 2" x 81"
11	Tube, Swaged, 7/8" x 84"
12	Tube, Swaged, 7/8" x 72"



Item No.	Description	Item No.	Description
1	Bracket, cast aluminum	25	Bolt, hex, cap, 5/16"-18 x 2 3/4"
7	Clamp, Boom-to-Bracket	26	Bolt, hex head, 5/16"-18 x 4"
8	Clamp, Casting-to-Boom	27	Nut, hex, 5/16"-18
10	Tube, Boom Section, 2" x 81"	28	Nut, hex, 1/4"-20
19	Bolt, hex head, 5/16"-18 x 3"	31	Lockwasher, split, 5/16"
20	Bolt, hex head, 5/16"-18 x 5"	33	Lockwasher, internal, 1/4"
24	Bolt, hex head, 1/4"-20 x 3/4"		

Figure 2  
Boom-to-Mast Detail

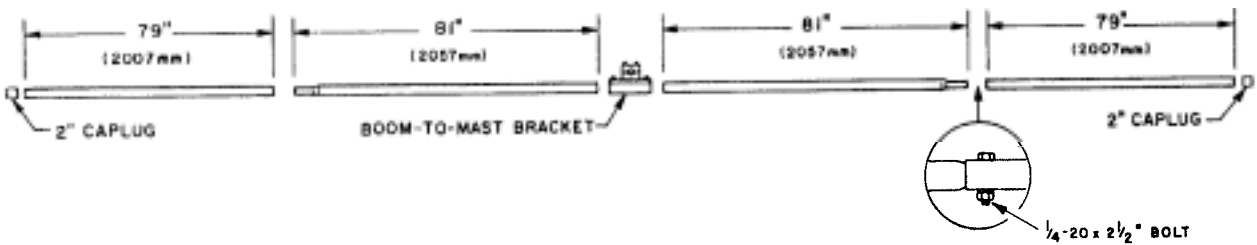
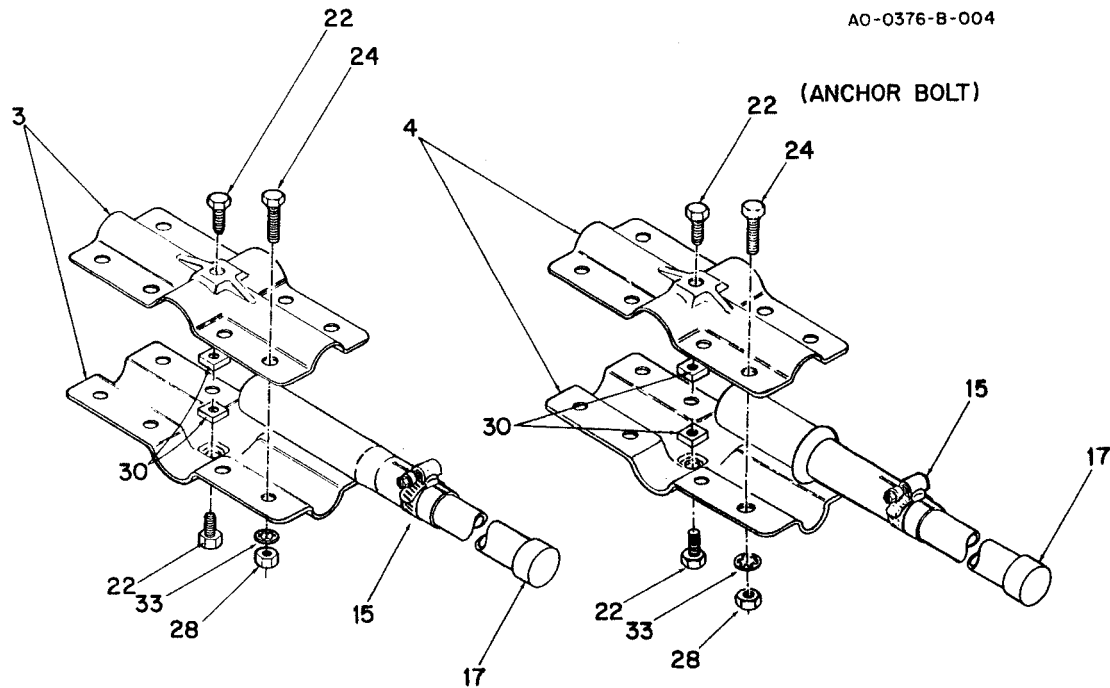

Figure 3  
Boom Assembly



Item No.	Description	Item No.	Description
3	Bracket, Element-to-Boom, #4	24	Bolt, hex head, 1/4"-20 x 3/4"
4	Bracket, Element-to-Boom, #13	28	Nut, hex, 1/4"-20
15	Clamp, #6 Tubing	30	Nut, square, 1/4"-2-0
17	Caplug, 7/16"	33	Lockwasher, internal, 1/4"
22	Bolt, hex head, 1/4"-20 x 3/8"		

Figure 4  
Element-to-Boom Brackets

### Assembly of Driven Element and Beta Match

NOTE: The following steps will have to be done first for one side of the boom then repeated for the other side.

Select the DE1 section of tubing. Slip the unswaged end of the DE 1 into a Driven Element insulator as shown in Figure 4. Slip the insulated end of the DE1 into the bracket assembly on the boom. Tighten the bolts to hold the element securely in the center of the bracket at this time.

Select the 1/4" beta rods. Attach the Beta Match to the boom as shown in Figure 8. Loosely attach the opposite ends of the beta rods to the tubing clamps on the Driven Element.

Do Not tighten these bolts at this time, the feedline will attach to this point in a later step. See Figure 8.

Check the Driven Element to see if it will lie in a plane parallel to the earth, then tighten the anchor bolts in the bracket securely.

### Installation of Tubing Clamps

Select the #6 tubing clamp as shown in the chart. When installing the clamps, place the clamp near the tube end with the top of the clamp over the slot in the tube as shown in Figure 5.

After adjustment of the tubing lengths, tighten the clamp with a 5/16 inch nut driver, socket, or open end wrench until the tubing will not twist or telescope.

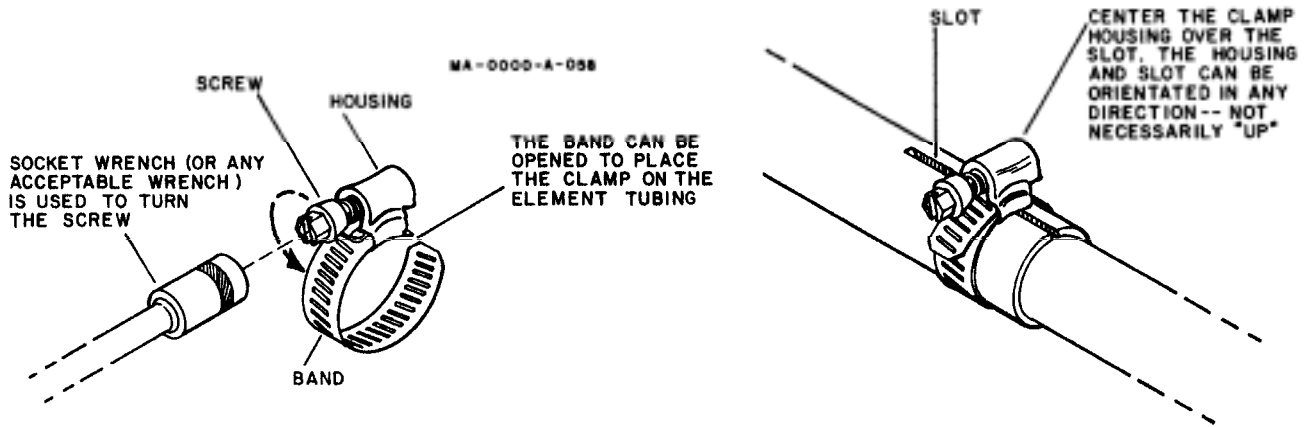

Part  
No.  
358756

Description  
Clamp, size #6  
all stainless steel  
5/16" hex head screw

Fits  
Tubing Sizes  
1/2  
and 3/4

Figure 5  
Tubing Clamp Installation

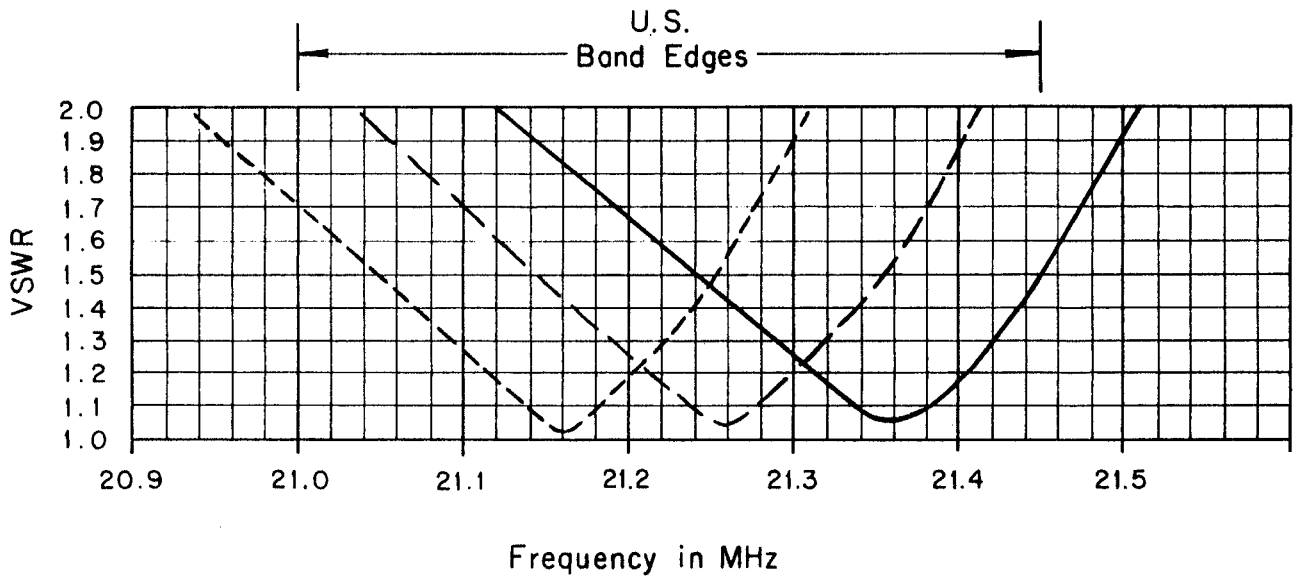
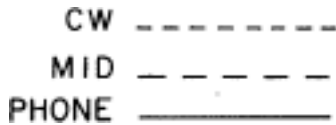
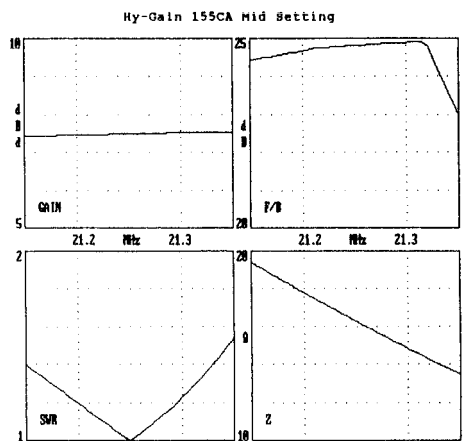
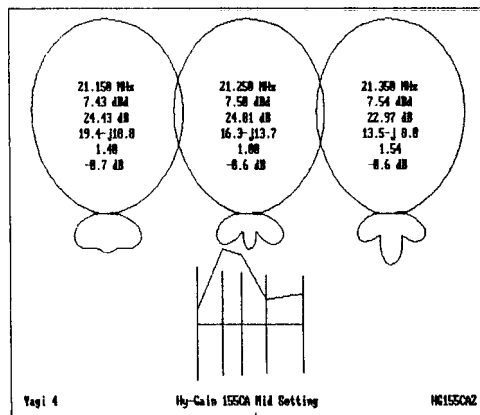

Figure 6  
VSWR Chart

NOTE: The VSWR Chart is typical of the 155CA when mounted at least 50 feet (15.2 m) above ground and at least 10 feet (3 m) from another HF antenna. The antenna should also be mounted in the clear - at least 30 feet (10 m) from any large metallic object such as a metal roof, anchor tower structure or parallel guy wires



HG 155CA MID SETTING				
21.150	21.250	21.350	21.250	MHz
5 elements, inches	1.0000	0.8750	0.5000	0.4375
0.000	3.6250	78.1250	3.2500	65.0000
73.000	3.6250	66.1250	3.2500	66.0000
130.000	3.6250	66.1250	3.2500	63.6250
203.000	3.6250	66.1250	3.2500	55.7500
309.000	3.6250	66.1250	3.2500	55.1250

NOTE: First column is the element spacing in inches. The first row is the element diameter in inches. All other rows are element section lengths.

Figure 7  
Sample YO version 4.0 Output Screen  
and Input File for the 155CA

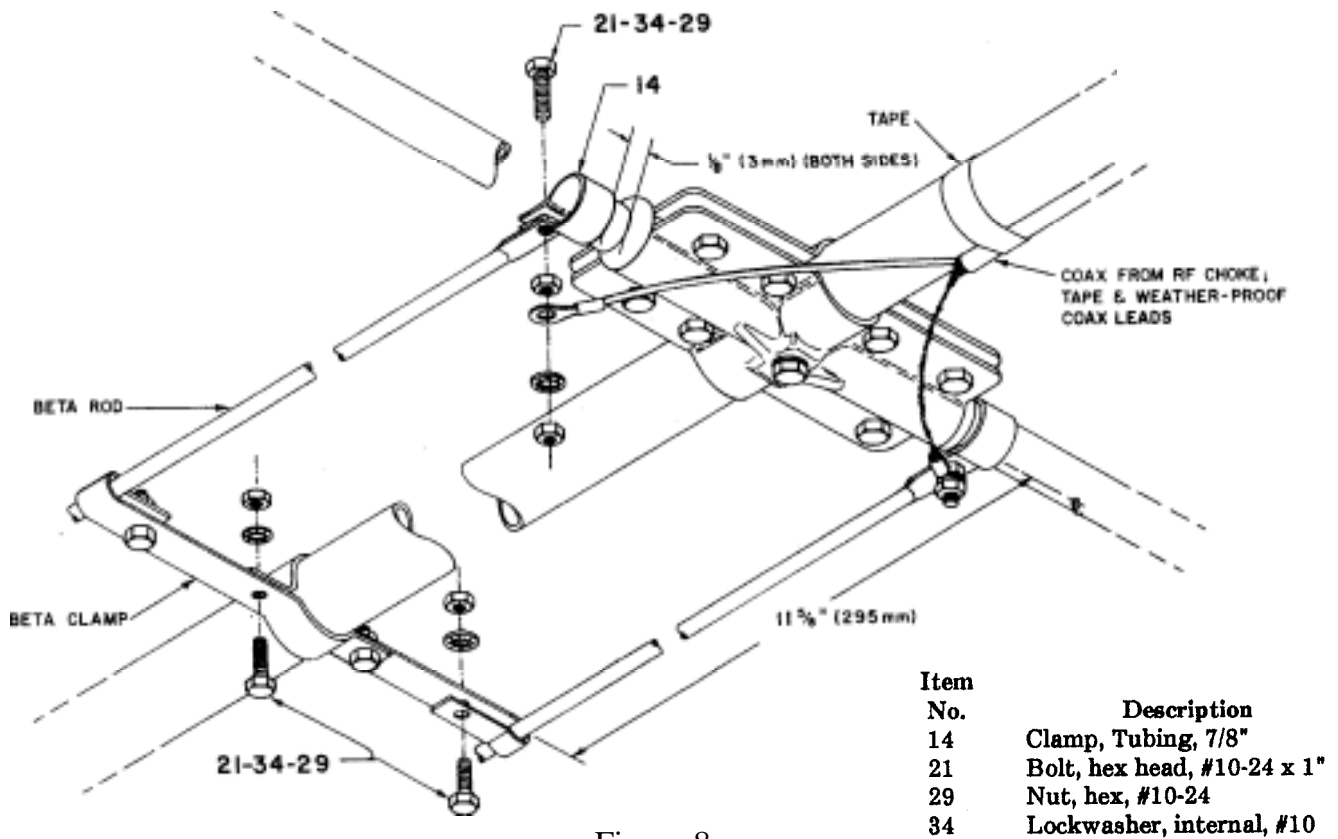

Figure 8  
Beta Match Assembly

### Assembly of the Reflector

Select the R1 section of tubing and slip the unswaged end into the bracket assembled on the boom. Tighten the bolts to hold the element securely, but do not tighten the anchor bolts in the center of the bracket at this time.

Check the Reflector Element to see if it will lie in the same plane as the Driven Element. Carefully recheck the distance from the Driven Element, then tighten the anchor bolts ~~securely~~.

Assemble the remainder of the Reflector Element in the same manner as the Driven Element. Refer to Figure 1 for tubing descriptions and dimensions and to Figure 5 for tubing clamp installation.

### Assembly of Director

Select the D1-1 section of tubing and slip the unswaged end into the bracket assembled on the boom. Tighten the screws to hold the element securely, but do not tighten the anchor bolts at this time.

Check the Director to see if it will lie in the same plane as the other elements and carefully recheck the distance from the Driven Element. Tighten the anchor bolts ~~securely~~.

Assemble the remainder of the Director Element in the same manner as the previous elements. Refer to Figure 1 for tubing descriptions and dimensions and to Figure 5 for tubing clamp installation.

Tighten all tubing clamps securely. Be careful not to overtighten.

Refer to "Rope Dampening Installation" and Figure 9.



Assemble the two remaining directors in the same manner as the previous elements. Refer to Figures 1 and 5.

Refer to "Rope Dampening Installation" and Figure 9.

### Rope Dampening Installation

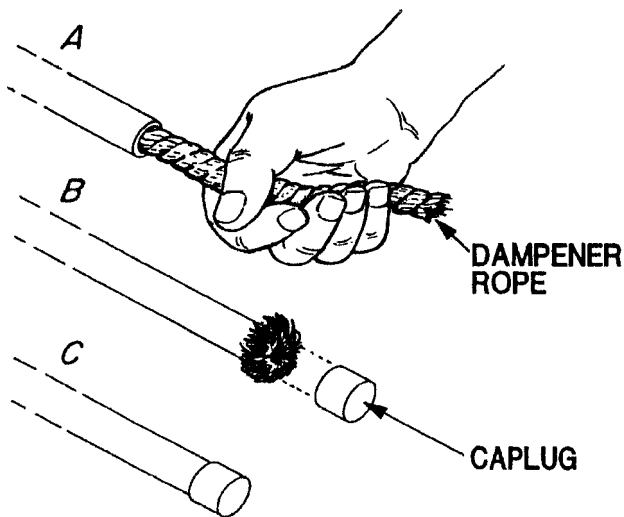

Figure 9 Rope Dampening

Select the rope and cut it into ten (10) equal lengths of six feet. Slip a length of rope into the end of each element. With about a half inch (13 mm) of rope extending from the element end separate the fibers and fold them back over the element and rope. The rope inside the element will prevent vibrations caused by low wind velocities.

### Feedpoint Configurations

A balun is required for normal operation of this antenna. However, there are three recommended feedpoint configurations, one of which utilizes the Hy-Gain Model BN-86 and BN-4000 baluns for increased performance and convenience.

The first feedpoint configuration involves connection of the coaxial feedline directly to the driven element. The recommended feedline is RG-213/U (such as Belden 8267). Other types of coaxial cable may be used if proper selection and careful assembly are utilized. The feedline should be stripped as shown in Figure 10. Attach solder lugs (not supplied) to the center conductor and shield for easy connection to the driven element. Weatherproof this connection.

The second feedpoint configuration involves construction and installation of a homemade RF choke. The RF choke will prevent RF from flowing on the outside of the coaxial shield. This will block radiation from the coaxial feedline, thereby reducing the risk of TVI and preventing radiation pattern degradation.

Wind the RF choke from RG-213[U (or equivalent) coaxial cable. The choke should consist of 12 turns with an inside coil diameter of 6 inches (152 mm). Allow enough cable at the end to reach from the mast to the driven element. Strip the coaxial cable as shown in Figure 10. Attach solder lugs (not supplied) to the center conductor and shield for easy connection to the driven element. Weatherproof this connection. RF choke should be placed as close to the feedpoint as possible.

The third feedpoint configuration using a 50 ohm 1:1 balun to connect the feedline to the driven element. (Hy-Gain Model BN-86 and BN-4000 are recommended.) A balun will act as an RF choke and will balance the flow of current on the driven element, resulting in a symmetrical radiation pattern. A balun will also have a coaxial connector, providing more convenience than a coax splice. Follow the instructions supplied with the balun for connection to the antenna.

NOTE: Use caution when selecting a balun to use with this antenna. Some baluns are designed for 50-75 ohm impedance and may result in a higher SWR when used with this antenna. For best results, use the Hy-Gain BN-86 or BN-4000 50 ohm baluns. Models BN-86 and BN-4000 are available at your local Hy-Gain dealer.

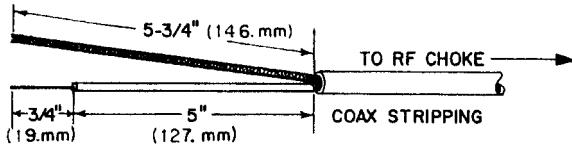

Figure 10  
Coax Stripping Dimensions

**WARNING**

Installation of this product near power lines is dangerous. For your safety, follow the installation directions.

**Installing the Antenna**

There are two recommended methods for getting the antenna to the top of the tower.

Method One - Completely assemble the antenna on the ground, then hoist it into position using the set-up shown in Figure 11.

Method Two - Assemble the antenna on the ground in halves, then hoist each half up the tower and assemble on the boom-to-mast bracket on the tower as shown in Figure 12.

Mount the antenna on your mast using one of the two methods given. Tighten all bolts in the boom-to-mast bracket securely.

You may wish to drill a 5/16" hole through the cast brackets' center hole and through the mast and secure using a 5/16"-18 x 4" bolt, lockwasher and nut (Item No.s 26, 27, & 31). This bolt will prevent the antenna from twisting on the mast in high winds. See Figure 2.

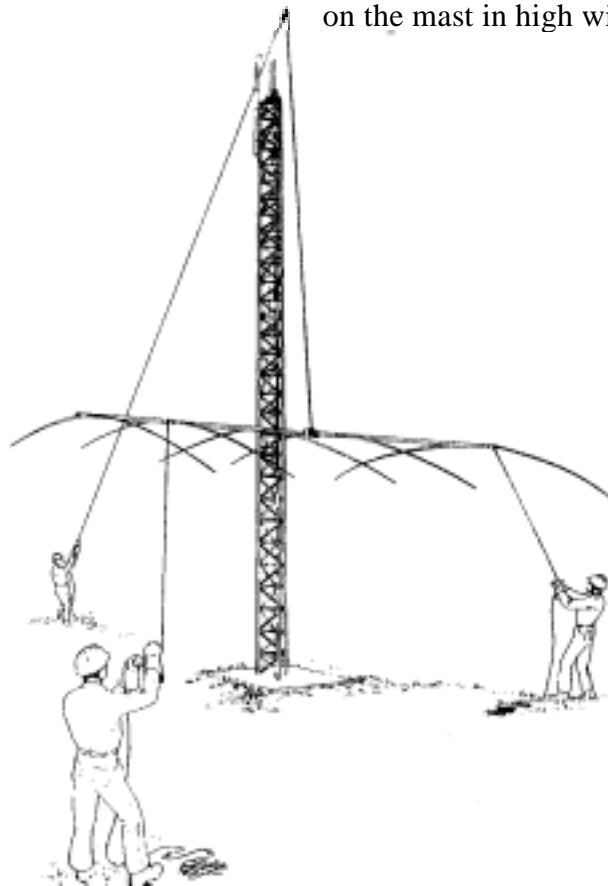

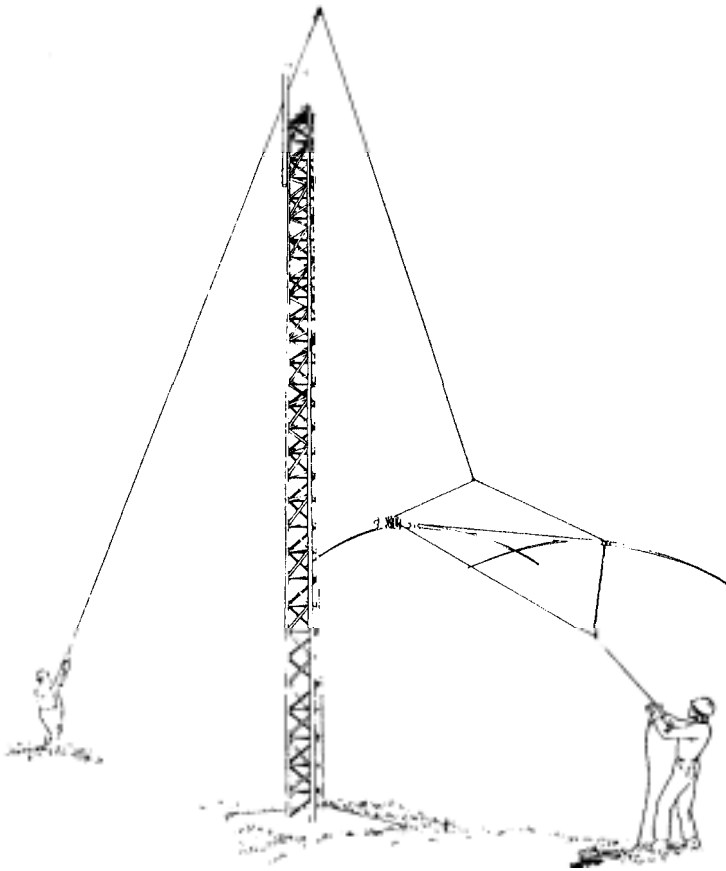

**Figure 12 Raising Antenna In Sections To Top Of Mast**

NOTE: The boom-to-mast brackets have a hole through their centers to allow securing to the mast with the 5/16"-18 x 3 1/2" bolt. It is recommended that the mast be removed and a 11/32" (9 mm) hole be drilled at the desired mast clamp position, then reinstall the mast. If this is not possible, the clamp will hold its position on the mast in all but the most severe weather conditions.

Securely tape the feedline to the mast and your antenna is ready to use.

### Weatherproofing

To ensure optimum performance, weather-proof all coaxial connections with Coax-SealB or another similar substance.

### Lightning Protection

You must ground your antenna supporting structure. This will also insure noise-free operation. A proper ground consists of a 1/2"-8' copper clad, steel ground rod driven into the ground as close as possible to the base of your tower or mast. Connect the rod to the tower or mast using #8 copper wire and non-corrosive clamps.

### Stacking the 205CA with the 155CA and the 105BA-S

If you choose to stack the 205CA and the 155CA in a Christmas tree fashion, you must use a very heavy mast. Recommended mast material is 1027 cold drawn carbon steel tubing, 20 feet long, two inch O.D. minimum, 1/2" wall thickness minimum. The 1027 cold drawn tubing has a yield strength of approximately 70,000 p.s.i.. If this is not available, you could also use 1018, 1020, 1025, or 1026 cold drawn tubing. These have yield strengths ranging from 55,000 to 65,000 p.s.i.. Whatever you choose, you should check the yield strength specified by the manufacturer. If you cannot obtain high strength tubing, you should increase the O.D. or the wall thickness.

Recommended spacings for the 205CA, 155CA and 105BA-S are listed below.

- 205CA- 6 inches above the tower
- 155CA- 9 feet above the 205CA
- 105BA-S - 7 feet above the

Using the spacings and the recommended mast with dimensions of two inch O.D. and 1/2" wall, you will have a moment of 3415 foot-pounds at the top of the tower in an 80 mph wind and a flexural strength of approximately 55,684 p.s.i.. Using 1027 cold drawn steel tubing, this will give you a safety factor of about 1.26:1.

The spacings listed above will minimize the wind load on the mast and tower and minimize interactions between the antennas.

# 155CA

## Maximum Front-to-Back Setting (155 MAX)

The 155CA may be tuned to produce 40 dB front-to-back at 21.250 MHz. On this setting, the front-to-back will be greater than 28 dB from 21.150 to 21.350 MHz, and the gain will be 9.15 dBi (7.0 dBd). The element spacing remains the same for this setting, however the lengths of the elements change:

R2 = 60 5/8"	(1.540 m)
DE2 = 66"	(1.676 m)
D1-2 = 63 7/8"	(1.622 m)
D2-2 = 45 7/8"	(1.165 m)
D3-2 = 48"	(1.219 m)

## 12 Meter (24.9 MHz) Setting

The 155CA may be tuned to 24.9 MHz by adjusting only the element lengths. When set to these dimensions the antenna is called the 125CA.

The 125CA features a 28 dB front-to-back ratio and 9.9 dBi (7.75 dBd) gain at 24.9 MHz. The VSWR is less than 1.5 from 24.890 to 24.990 MHz. The new element lengths are:

R2 = 40 1/8"	(1.019 m)
DE2 = 43 7/8"	(1.114 m)
D1-2 = 42"	(1.067 m)
D2-2 = 36"	(0.914 m)
D3-2 = 32 1/8"	(0.816 m)

The Beta Match dimensions remain the same for both optional settings.

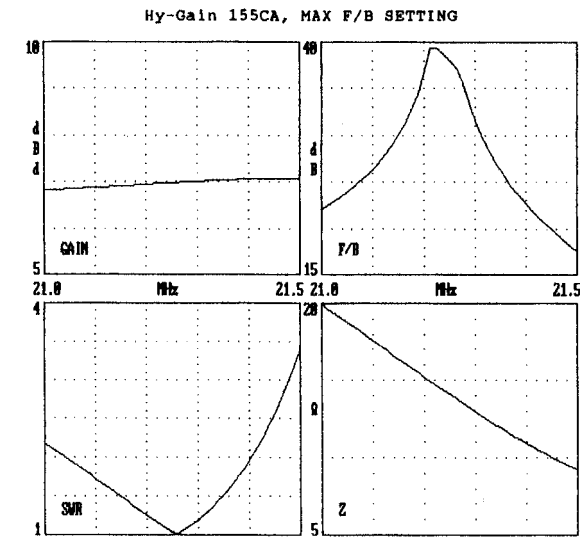
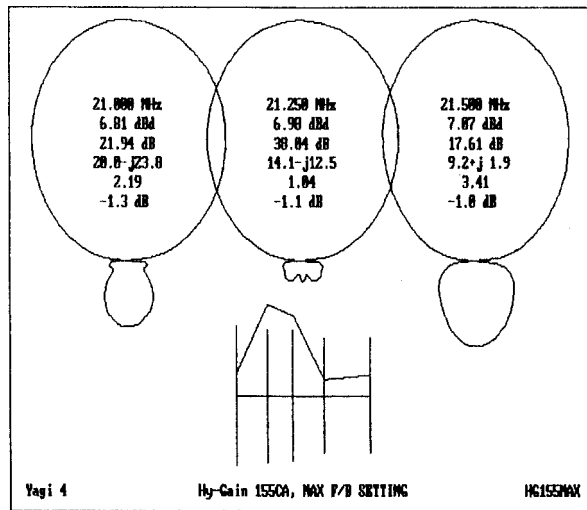

### HG155CA MAX F/B SETTING

	21.000	21.250	21.500	21.260	MHz
5 elements, inches					
	0.000	1.0000	0.8750	0.5000	0.4375
	73.000	3.6250	66.1250	3.2500	60.6250
	130.000	3.6250	66.1250	3.2500	66.0000
	203.000	3.6250	66.1250	3.2500	63.8750
	309.000	3.6250	66.1250	3.2500	45.8750
					48.0000

NOTE: First column is the element spacing in inches. The first row is the element diameter in inches. All other rows are element section lengths.

Figure 13  
Sample YO© version 4.0 Output Screen and Input File  
for the 155CA Maximum FB Setting.

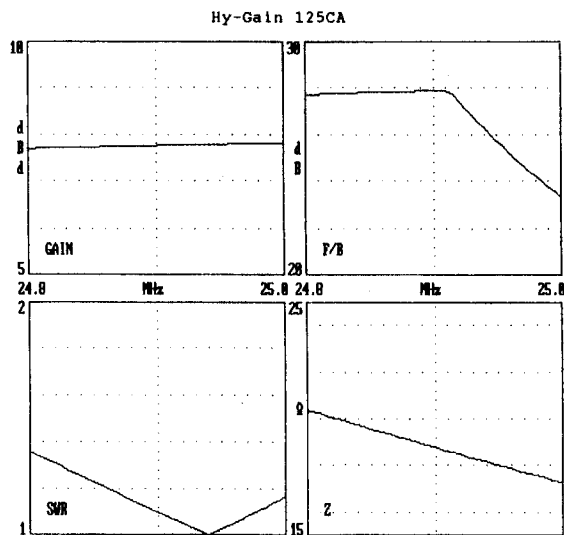
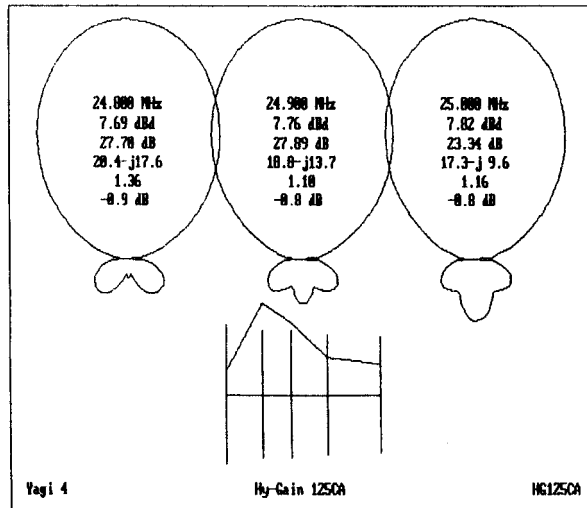

HG125CA					
	24.800	24.900	25.000	24.940	MHz
5 elements, inches					
	0.000	1.0000	0.8750	0.5000	0.4375
	73.000	3.6250	78.1250	3.2500	40.1250
	130.000	3.6250	66.1250	3.2500	43.8750
	203.000	3.6250	66.1250	3.2500	42.0000
	309.000	3.6250	66.1250	3.2500	36.0000
					32.1250

NOTE: First column is the element spacing in inches. The first row is the element diameter in inches. All other rows are element section lengths.

Figure 14  
Sample YO© version 4.0 Output Screen and Input File  
for the 125CA Option

## PARTS

Item			Description Qty
No.	<b>Part No.</b>		
1	102734	Bracket, cast aluminum.....	2
2	163371	Clamp, beta .....	2
3	163764	Bracket, element-to-boom, #4.....	8
4	165919	Bracket, element-to-boom, #13.....	2
5	175943	Rod, beta, 1/4" x 117/8" .....	2
6	174868	Tube, 7/16" x 68" .....	10
7	172732	Clamp, boom-to-bracket .....	1
8	172735	Clamp, casting-to-boom.....	1
9	171029	Tube, boom section, 2" x 79" .....	2
10	871048	Tube, inner boom, 2" x 81" .....	2
11	174862	Tube, swaged, 7/8" x 84" .....	2
12	190100	Tube, swaged, 7/8" x 72" .....	8
13	871842	Parts Pack 376S, stainless steel.....	1
14	163312	Clamp, tubing, 7/8" .....	2
15	358756	Clamp, #6 tubing.....	10
16	455625	Caplug, 2" .....	2
17	455644	Caplug, 7/16" .....	10
18	463767	Insulator, 7/8" ID x 1 1/4" OD .....	2
19	500392	Bolt, hex head, 5/16"-18 x 3".....	2
20	500349	Bolt, hex head, 5/16"-18 x 5".....	4
21	504069	Bolt, hex head, #10-24 x 1" .....	7
22	500156	Bolt, hex head, 1/4"-20 x 3/8".....	12
23	505734	Bolt, hex head, 1/4"-20 x 2 1/2.....	2
24	505266	Bolt, hex head, 1/4"-20 x 3/4".....	46
25	506968	Bolt, hex, cap, 5/16"-18 x 2 3/4".....	2
26	5142400	Bolt, hex head, 5/16"-18 x 4.....	1
27	555747	Nut, hex, 5/16"-18.....	9
28	554099	Nut, hex, 1/4"-20 .....	52
29	554071	Nut, hex, #10-24 .....	7
30	551367	Nut, square, 1/4"-20.....	12
31	564792	Lockwasher, split, 5/16".....	9
32		(Not Used)	
33	562961	Lockwasher, internal, 1/4" .....	50
34	565697	Lockwasher, internal #10.....	8
35	690190	Rope, black poly, 5/32" x 60'.....	1

## **hy-gain**® LIMITED WARRANTY

**Hy-Gain** Warrants to the original owner of this product, if manufactured by **Hy-Gain** and purchased from an authorized dealer or directly from **Hy-Gain** to be free from defects in material and workmanship for a period of 12 months for rotator products and 24 months for antenna products from date of purchase provided the following terms of this warranty are satisfied.

1. The purchaser must retain the dated proof-of-purchase (bill of sale, canceled check, credit card or money order receipt, etc.) describing the product to establish the validity of the warranty claim and submit the original or machine reproduction of such proof of-purchase to **Hy-Gain** at the time of warranty service. **Hy-Gain** shall have the discretion to deny warranty without dated proof-of-purchase. Any evidence of alteration, erasure, or forgery shall be cause to void any and all warranty terms immediately.
2. **Hy-Gain** agrees to repair or replace at **Hy-Gain's** option without charge to the original owner any defective product under warranty, provided the product is returned postage prepaid to **Hy-Gain** with a personal check, cashiers check, or money order for \$8.00 covering postage and handling.
3. Under no circumstances is **Hy-Gain** liable for consequential damages to person or property by the use of any **Hy-Gain** products.
4. Out-of-warranty Service: **Hy-Gain** will repair any out-of-warranty product provided the unit is shipped prepaid. All repaired units will be shipped COD to the owner. Repair charges will be added to the COD fee unless other arrangements are made.
5. This warranty is given in lieu of any other warranty expressed or implied.
6. **Hy-Gain** reserves the right to make changes or improvements in design or manufacture without incurring any obligation to install such changes upon any of the products previously manufactured.
7. All **Hy-Gain** products to be serviced in-warranty or out-of-warranty should be addressed to **hy-gain, 308 Industrial Park Road, Mississippi 39759, USA** and must be accompanied by a letter describing the problem in detail along with a copy of your dated proof-of-purchase.
8. This warranty gives you specific rights, and you may also have other rights which vary from state to state.